

# LCZ-UM20-IN 20W Ceiling Loudspeaker

www.boschsecurity.com



**BOSCH**  
Invented for life



- ▶ Excellent speech and music reproduction.
- ▶ High sound pressure level.
- ▶ Ideal for high ceiling applications.

The LCZ-UM20-IN is a 20 W loudspeaker with integrated circular metal grille. It has excellent audioperformance and is easy to install with its integral mounting clips. The loudspeaker is suitable for high ceiling applications.

## Functions

The LCZ-UM20-IN has a perforated metal grille, finished in an attractive off-white color. The LCZ-UM20-IN has a single piece 20W, dual cone loudspeaker. A 100V matching transformer is mounted on the back of the frame. It can be used in areas with high ceiling as well as in shops, departmental stores, offices, sports halls, hotels and restaurants. The loudspeaker has been tested for operating at rated power for 100 hours in accordance with IEC268-5 Power Handling Capacity (PHC) standards.

## Installation/configuration notes

Installation is easy with integral clips that securely hold the ceiling loudspeaker in its cut-out. The line matching transformer mounted on the ceiling loudspeaker can be tapped for nominal full power, half power and quarter power radiation to adjust in 3dB steps.

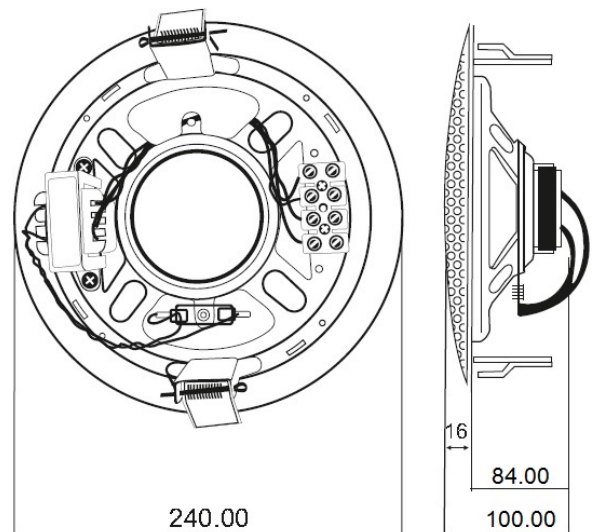

Dimensions in mm

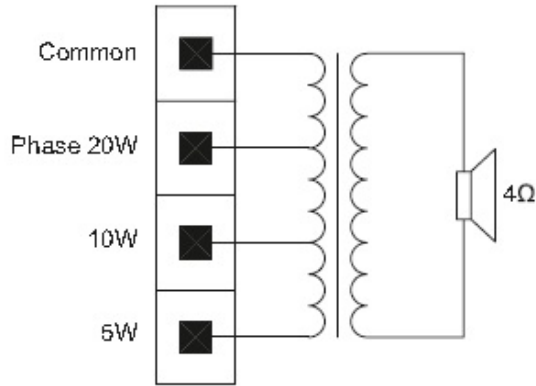

Circuit Diagram

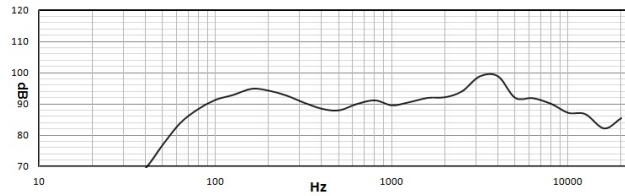

Frequency Response

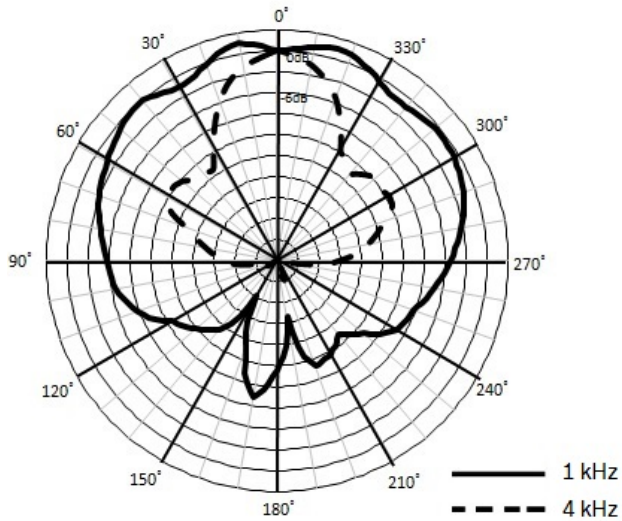

Horizontal Polar Diagram

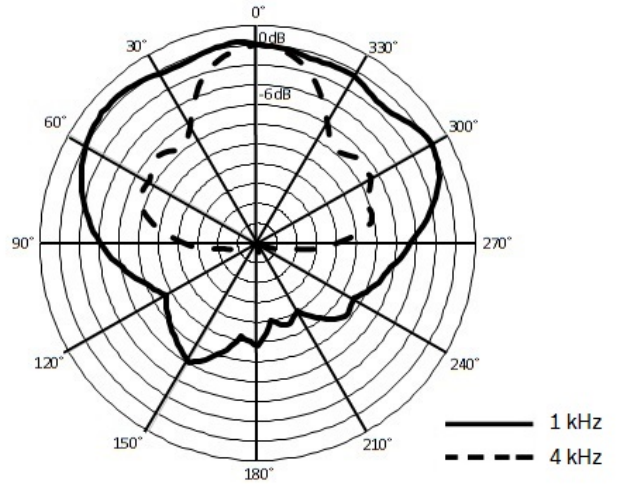

Vertical Polar Diagram

**Technical specifications**

**Electrical**

Rated Power	20W
Sound Pressure Level at 20W/1 W (1 kHz, 1 m)	104 dB / 91 dB
Effective frequency range	100 Hz to 15 kHz(-10dB)
Opening angle (1kHz/4kHz,-6dB)	176° / 44°
Rated Impedance	500 Ohm
Rated input voltage	100V
Connector	4 Pole Screw Terminal

**Mechanical**

Diameter(in mm)	240
Depth(in mm)	100
Weight	1.6 kg
Colour	Off White

**Environmental**

Operating temperature	-5 °C to +55 °C
Storage temperature	-40 °C to +70 °C

**Ordering information**

**LCZ-UM20-IN 20W Ceiling Loudspeaker**  
Order number **LCZ-UM20-IN**

**Represented by:**

**Americas:**

Bosch Security Systems, Inc.  
130 Perinton Parkway  
Fairport, New York, 14450, USA  
Phone: +1 800 289 0096  
Fax: +1 585 223 9180  
security.sales@us.bosch.com  
www.boschsecurity.us

**Europe, Middle East, Africa:**

Bosch Security Systems B.V.  
P.O. Box 80002  
5617 BA Eindhoven, The Netherlands  
Phone: + 31 40 2577 284  
Fax: +31 40 2577 330  
emea.securitysystems@bosch.com  
www.boschsecurity.com

**Asia-Pacific:**

Robert Bosch (SEA) Pte Ltd, Security  
Systems  
11 Bishan Street 21  
Singapore 573943  
Phone: +65 6571 2808  
Fax: +65 6571 2699  
apr.securitysystems@bosch.com  
www.boschsecurity.asia

**China:**

Bosch (Shanghai) Security Systems Ltd.  
201 Building, No. 333 Fuquan Road  
North IBP  
Changning District, Shanghai  
200335 China  
Phone +86 21 22181111  
Fax: +86 21 22182398  
www.boschsecurity.com.cn

**America Latina:**

Robert Bosch Ltda Security Systems Division  
Via Anhanguera, Km 98  
CEP 13065-900  
Campinas, Sao Paulo, Brazil  
Phone: +55 19 2103 2860  
Fax: +55 19 2103 2862  
latam.boschsecurity@bosch.com  
www.boschsecurity.com